

Blending chaotic attractors using the synchronization of chaos

Henry D. I. Abarbanel,¹ Nikolai F. Rulkov,² and Mikhail M. Sushchik³

¹*Department of Physics and Scripps Institution of Oceanography, University of California, San Diego, La Jolla, California 92093-0402*

²*Institute for Nonlinear Science, University of California, San Diego, La Jolla, California 92093-0402*

³*Department of Physics and Institute for Nonlinear Science, University of California, San Diego, La Jolla, California 92093-0402*

(Received 27 February 1995)

Building a source of low-dimensional chaotic signals with specified properties poses new challenges in the study of nonlinear systems. We address this problem using two synchronized asymmetrically coupled chaotic systems. As an uncoupled oscillator, each produces chaotic signals with distinctively different properties. The chaotic signal produced by the synchronized oscillators possesses properties intermediate with respect to the two original signals. The properties of this synthesized signal can be controlled by the ratio of the coupling parameters.

PACS number(s): 05.45.+b, 84.30.Ng

It has become straightforward to evaluate various characteristics of a physical system using scalar observations from the system, even when the output is chaotic [1]. The problem of designing a chaotic source which produces chaotic signals with specified properties still remains challenging. It would be quite interesting to build “designer chaotic sources” with specified properties for various uses. At this time one often focuses on a limited number of available chaotic systems instead of designing ones well fit for a chosen purpose. While the general mathematical solution of this problem does not appear possible at this time, we suggest a method that appears to provide a practical solution in many instances. For many applications of chaos (e.g., communication), it is desirable to have a chaotic signal, which corresponds to low-dimensional chaotic attractors so that one can easily keep the system under control [2]. To generate this kind of signal with desired properties we propose a method which relies upon using the mutual synchronization of chaotic motions [3,4]. The synchronization of *periodic* motions is a convenient tool which is widely used for control of the characteristics of periodic signals [5]. However, we will use synchronization of *chaotic* motions for synthesis of chaotic signals.

We start with two chaotic signal generators each producing a chaotic output signal. The parameters of these two sources are distinct. We use these two generators to construct another which will produce chaotic output having different properties but still corresponding to a low-dimensional attractor. To achieve this goal we couple two generators using their output terminals. When the coupling is sufficiently strong, chaotic oscillations in the two systems become synchronized. This leads us to a class of low-dimensional attractors among which we can make our choice by varying the mutual coupling all the while remaining in the regime of overall synchronization. The main point of using systems which are synchronized is that the attractor in the phase space remains low di-

mensional even though by coupling two systems we increase the dimension of the total phase space. This is critical to the eventual utility of the output of the coupled system as high-dimensional chaotic attractors still pose difficult computational and control issues. In this paper we discuss our general idea and then illustrate the method experimentally using two coupled chaotic electronic circuits. We demonstrate that in our example it is possible to predict the properties of the chaotic output from the new generator.

To describe the method we write the differential equations describing the dynamics of the two uncoupled chaotic oscillators as

$$\dot{X} = F(X, \mathbf{x}), \quad (1)$$

$$\dot{\mathbf{x}} = \mathbf{f}(X, \mathbf{x}),$$

$$\dot{Y} = G(Y, \mathbf{y}), \quad (2)$$

$$\dot{\mathbf{y}} = \mathbf{g}(Y, \mathbf{y}).$$

The scalars X and Y are the output signals of the sources. The vectors \mathbf{x} and \mathbf{y} describe the dynamics of the remaining degrees of freedom of the oscillators. Call the chaotic attractor of system (1) CA_X of system (2) CA_Y . We couple these via

$$\dot{X} = F(X, \mathbf{x}) + g_X(Y - X), \quad (3)$$

$$\dot{Y} = G(Y, \mathbf{y}) + g_Y(X - Y).$$

We assume that when either g_X or g_Y is sufficiently large, the chaotic oscillations in subsystems (X, \mathbf{x}) and (Y, \mathbf{y}) become synchronized [4]. As a function of the ratio $\rho = (g_X/g_Y)$ the overall attractor CA_C of the coupled system goes to CA_X when $\rho \rightarrow 0$, and the CA_Y when $\rho \rightarrow \infty$. As ρ changes over this range the coupled system attractor CA_C possesses properties intermediate with respect to the properties of the original attractors. We designate this transformation of attractors: “blending” chaotic at-

tractors. When the original two attractors possess distinctively different properties, the properties of the attractor CA_C that appears as a result of such blending can vary significantly, thus providing a wide choice of attractors from which the most desirable can be selected. At the same time, since chaotic oscillations in the two subsystems are synchronized, the coupling does not significantly increase the complexity of the signal leaving the system low-dimensional, controllable, and therefore useful for many applications.

Although in this description we made a few limiting restrictions, we now demonstrate that this method can be easily employed in practice. As an example we create a family of blended chaotic attractors by coupling two chaotic electronic circuits which are synchronized by means of asymmetric dissipative linear coupling.

The circuit diagram of the two coupled nonlinear circuits is shown in Fig. 1. See [6] for more details. Asymmetric coupling is provided by resistors R_X and R_Y which follow the buffers. Note that the strengths of the couplings g_X and g_Y are inversely proportional to the values of R_X and R_Y . In the experimental setup the parameters of the circuits were chosen to be $C_1=334$ nF, $C_2=331$ nF, $C'_1=221$ nF, $C'_2=219$ nF, $L_1=L_2=144.9$ mH, $r_1=347$ Ω , $r_2=349$ Ω , $R_1=3.10$ k Ω , and $R_2=3.19$ k Ω . We use the gain at zero of the input voltage as the control parameter of the nonlinear converter. The gains of the nonlinear converters were set in such a way that $\alpha_X=15.1$ and $\alpha_Y=19.2$. The reason for this particular selection of the parameters of the circuits is that in this case two uncoupled circuits have chaotic attractors with distinctively different properties. The projections of these attractors reconstructed by means of time delay embedding [1] are shown in Figs. 2(a) and 2(b).

In the experiment we fixed the value of the Y coupling resistor $R_Y=76.2$ Ω . We found experimentally that for this value of R_Y the chaotic oscillations in two circuits were synchronized regardless of R_X . In the synchronization regime $|X(t)-Y(t)|$ was less than 50 mV, while the maximum amplitude of $X(t)$ ranged around 2 V. The onset of synchronized chaos was also confirmed by analysis of local dimensions of the time series using the local false nearest neighbors technique [1]. This analysis clearly indicated that the local dimension of the attractor CA_C remained equal to 3 throughout the experiment just as in each of the two uncoupled systems.

By varying R_X from 0 to ∞ we observed a bifurcation

sequence that describes the transition of attractor CA_C from attractor CA_X to attractor CA_Y . Both periodic and chaotic attractors with various properties are seen in this sequence. Thus we can select chaotic regimes that produce the outputs with properties varying within very wide limits. Some of the attractors associated with chaotic oscillations are shown in Fig. 3.

The signals corresponding to attractors shown in Figs. 3(b) and 3(c) are in Figs. 4(a) and 4(b). Each signal is a chaotic sequence of impulses. However, the first one is a sequence of impulses which have almost identical shape but alternate the sign in a chaotic fashion. The second is a sequence of impulses which change the sign periodically but the shape of the impulses bears a chaotic modulation. This difference can be detected by both looking at the time traces and by computing the autocorrelation function for the two time series. These functions are shown in Figs. 4(c) and 4(d).

In order to clarify the mechanism of blending chaotic attractors in the circuits let us consider a particular case when the elements of linear feedbacks in each circuit are identical, but the nonlinear elements have different amplification gains α_X and α_Y . The behavior of such coupled circuits is modeled by

$$\begin{aligned}\dot{X} &= x_1 + g_X(Y - X), \\ \dot{x}_1 &= -X - \delta x_1 + x_2, \\ \dot{x}_2 &= \gamma[\alpha_X f(X) - x_2] - \sigma x_1\end{aligned}\quad (4)$$

and

$$\begin{aligned}\dot{Y} &= y_1 + g_Y(X - Y), \\ \dot{y}_1 &= -Y - \delta y_1 + y_2, \\ \dot{y}_2 &= \gamma[\alpha_Y f(Y) - y_2] - \sigma y_1,\end{aligned}\quad (5)$$

where time has been rescaled, and $X(t)$, $x_2(t)$, $Y(t)$, and $y_2(t)$ are the voltages across the capacitors C_1 , C'_1 , C_2 , and C'_2 , respectively. $x_1(t)$ and $y_1(t)$ are the rescaled currents through the inductors $L_{1,2}$. The parameters δ , σ , and γ are positive and depend on the linear feedback loop. The coupling coefficients are given by $g_X=(1/R_X)(L_1/C_1)^{1/2}$ and $g_Y=(1/R_Y)(L_2/C_2)^{1/2}$.

We held the internal parameters fixed in our analysis and varied the couplings. When $g_X=g_Y=0$, each circuit exhibits chaotic oscillations and the corresponding at-

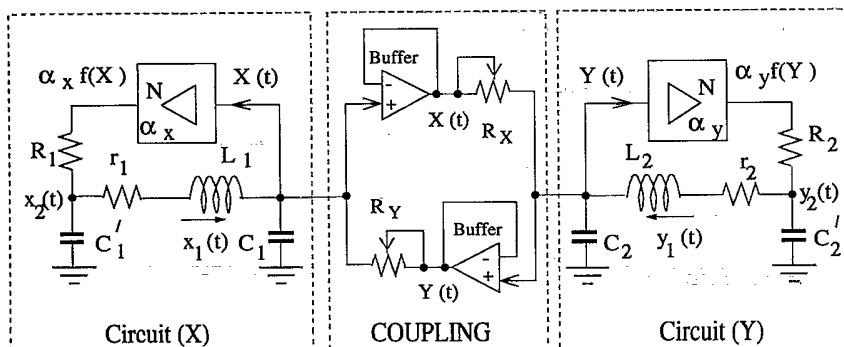

FIG. 1. Diagram of asymmetrically coupled chaotic circuits. N , nonlinear converter.

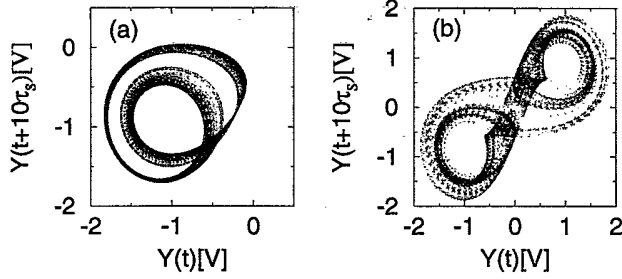

FIG. 2. The projections of attractors CA_X (a) and CA_Y (b) reconstructed by time delay embedding with time delay $10\tau_S$. The sampling time $\tau_S = 20 \mu\text{sec}$.

tractors do not have the same invariant properties. By coupling these different systems we create new attractors with properties possessed by neither original system. We observe the transformation that the attractor in the augmented system undergoes when ρ changes from 0 to ∞ keeping at least one of g_X, g_Y sufficiently large to provide synchronization of chaos in the two circuits.

It follows from the X and Y parts of Eqs. (4) and (5) that as long as $x_1(t), y_1(t), \dot{X}(t)$, and $\dot{Y}(t)$ are finite and at least one of g_X and g_Y is sufficiently large, trajectories in the phase space of the coupled circuits approach a manifold of slow motions where $X(t) \approx Y(t)$. This relation between $X(t)$ and $Y(t)$ is confirmed by experimental observations as well. If we introduce new variables

$$\begin{aligned} Z_1 &= \frac{g_Y X + g_X Y}{g_X + g_Y}, \quad z_1 = X - Y, \\ Z_2 &= \frac{g_Y x_1 + g_X y_1}{g_X + g_Y}, \quad z_2 = x_1 - y_1, \\ Z_3 &= \frac{g_Y x_2 + g_X y_2}{g_X + g_Y}, \quad z_3 = x_2 - y_2, \end{aligned} \quad (6)$$

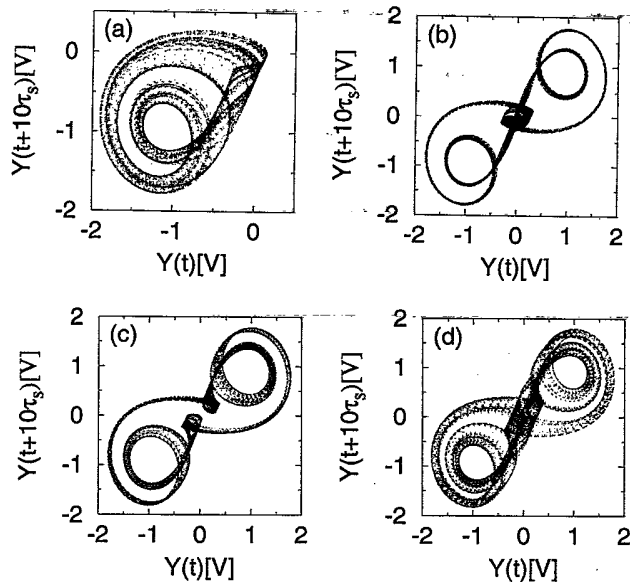

FIG. 3. The time delay reconstructed projections of chaotic attractors CA_Z for (a) $R_X = 54.5 \Omega$, (b) $R_X = 77 \Omega$, (c) $R_X = 106 \Omega$, (d) $R_X = 126 \Omega$.

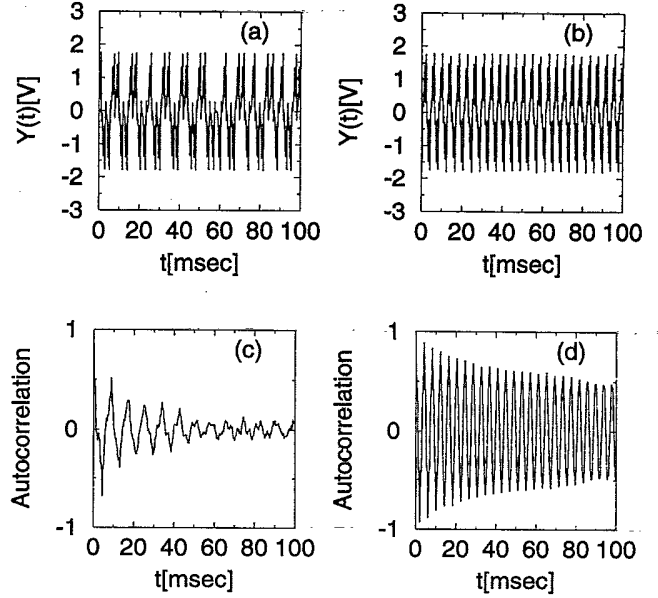

FIG. 4. The time series of $Y(t)$ for (a) $R_X = 77 \Omega$ and (b) $R_X = 106 \Omega$. (c) and (d) are the corresponding autocorrelation functions.

then the equations for the Z variables describe the dynamics of slow motions, and they decouple from the rest giving us

$$\begin{aligned} \dot{Z}_1 &= Z_2, \\ \dot{Z}_2 &= -Z_1 - \delta Z_2 + Z_3, \\ \dot{Z}_3 &= \gamma[\alpha f(Z_1) - Z_3] - \sigma Z_2, \end{aligned} \quad (7)$$

where

$$\alpha = \frac{g_X \alpha_X + g_Y \alpha_Y}{g_X + g_Y}. \quad (8)$$

This demonstrates that there is a limit set of the trajectories in the six-dimensional phase space of the original system (4), (5), that is associated with the attractor CA_Z of the autonomous three-dimensional system (7). Since a three-dimensional projection of this limit set is attracting in Z subspace, the stability of this limit set in the six-dimensional phase space is determined by the equations for the z variables which are

$$\begin{aligned} \dot{z}_1 &= z_2 - g z_1, \\ \dot{z}_2 &= -z_1 - \delta z_2 + z_3, \\ \dot{z}_3 &= -\gamma z_3 - \sigma z_2 + \gamma(\alpha_X + \alpha_Y) f(Z_1(t)), \end{aligned} \quad (9)$$

where $g = g_X + g_Y$. This system is linear and therefore the conditional Lyapunov exponents [7] of system (9), conditioned on the trajectories of the CA_Z , are the eigenvalues of the matrix

$$\begin{bmatrix} -g & 1 & 0 \\ -1 & -\delta & 1 \\ 0 & -\sigma & -\gamma \end{bmatrix}. \quad (10)$$

In the case of large g these become $\lambda_1 \approx -g$ and $\lambda_{2,3} \approx -\frac{1}{2}[\delta + \gamma \pm \sqrt{(\delta - \gamma)^2 - 4\sigma}]$. The Lyapunov exponent λ_1 corresponds to the fast motions towards the manifold of slow motions $X = Y$. The other two exponents determine the stability of the synchronized motions with respect to perturbations tangential to $X = Y$. These are always negative since $\gamma, \delta, \sigma > 0$. Therefore, when g is sufficiently large, the limit set, defined by (7) in the phase space of (4),(5), is attracting.

In the limit $g \rightarrow \infty$, it is possible to derive integral relations that transform the projection of the full system attractor onto the (X, x) subspace into the projection of this attractor onto the (Y, y) subspace and vice versa. So, when g is large enough, the chaotic oscillations in the two circuits are synchronized in a generalized sense [4,8]. A remarkable property of this manifold of synchronized motions is that it mimics the phase space of our individual nonlinear circuits with the value of α lying between α_X and α_Y . It follows from (8) that changing the ratio ρ for the two coupled circuits is equivalent to changing the effective value of α . By varying ρ over the range 0 to ∞ , we should be able to observe exactly the same sequence of bifurcations that takes place as the parameter α in system (7) is changed from α_Y to α_X . Thus, in this example we can create new chaotic signals by coupling and synchronizing two chaotic generators, and we can predict before-

hand the properties of that signal, since we know the properties of the circuit described by the Z motions. It is precisely the dynamics of the individual circuits in our coupled system with a new value of the parameter which in practice may not be adjustable.

The technique of "blending" of chaotic attractors based on the synchronization of chaos can be used to enrich the palette of chaotic signals while keeping them low dimensional and thus useful for various applications. In particular, one can synthesize symmetric chaotic attractors by synchronizing two chaotic systems which do not possess symmetric attractors. The method can be of special importance in those frequent cases when the control of the internal parameters of each individual system is limited.

We thank the members of INLS for numerous discussions on this subject. This work was supported in part by the U. S. Department of Energy, Office of Basic Energy Sciences, Division of Engineering and Geosciences, under Contract No. DE-FG03-90ER14138, and in part by the Army Research Office (Contract No. DAAL03-91-C-052), and by the Office of Naval Research (Contract No. N00014-91-C-0125), under subcontract to the Lockheed/Sanders Corporation.

-
- [1] H. D. I. Abarbanel, R. Brown, J. J. Sidorovich, and L. Sh. Tsimring, *Rev. Mod. Phys.* **65**, 1331 (1993).
- [2] E. Ott, C. Grebogi, and J. A. Yorke, *Phys. Rev. Lett.* **64**, 1196 (1990); Y-Ch. Lai and C. Grebogi, *Phys. Rev. E* **47**, 2357 (1993); S. Hayes, C. Grebogi, E. Ott, and A. Mark, *Phys. Rev. Lett.* **73**, 1781 (1994).
- [3] H. Fujisaka and T. Yamada, *Prog. Theor. Phys.* **69**, 32 (1983).
- [4] V. S. Afraimovich, N. N. Verichev, and M. I. Rabinovich, *Radiophys. Quantum Electron.* **29**, 795 (1986).
- [5] Ch. Hayashi, *Nonlinear Oscillations in Physical Systems* (McGraw-Hill, New York, 1964); I. I. Blekhman, *Synchronization in Science and Technology* (American Society of Mechanical Engineers, New York, 1988).
- [6] N. F. Rulkov, A. R. Volkovskii, A. Rodriguez-Lozano, E. Del Rio, and M. G. Velarde, *Int. J. Bif. Chaos* **2**, 669 (1992).
- [7] L. M. Pecora and T. L. Carroll, *Phys. Rev. Lett.* **64**, 821 (1990).
- [8] N. F. Rulkov, M. M. Sushchik, L. S. Tsimring, and H. D. I. Abarbanel, *Phys. Rev. E* **51**, 980 (1995).